



Scarab™

by **WERKMASTER™**



WerkMaster Scarab Small & Versatile Grinder & Polisher



The WerkMaster Scarab with Octi-Disc™ Technology is the ideal machine for floors, walls, stairs, risers, ledges and countertops.

7 Machines in 1 – Grinds, strips, sands, buffs, burnishes, polishes and edges right to the wall!

Excellent for concrete, stone, hardwood, terrazzo and VCT tile

- THE tool for professional contractors and DIYers
- Handheld for countertops, walls, ledges and risers; use with the optional, removable, upright handle for floors and stairs
- With 90° head rotation the Scarab is designed to get into tight places and small spaces – taking it to the wall
- The Scarab works with the Milwaukee, Metabo, Flex, DeWalt or Alpha variable speed polishers. The Octi-Disc™ self-balancing 5 head system is used with our ULTRA-FLEX Plug 'N Go tooling system and PCDs for tough coating removal or with standard 3" (76 mm) polishing pads

Scarab	
Footprint: IN (cm)	7 x 10 (18 x 25)
Disc Size: IN (cm)	3 (7.6)
Weight: LBS (Kg)	20 (9) w/o drive unit
Disc Speed Range: RPM	0-2800

Surface Substrate	Coverage
Glue sq ft/hr	10-25 sq ft
Paint sq ft/hr	10-25 sq ft
Epoxy sq ft/hr	10-25 sq ft
Thinset sq ft/hr	10-25 sq ft
Concrete sq ft/hr	10-100 sq ft

Please visit <http://www.werkmaster.com/product-videos/> for a demonstration of techniques using WerkMaster Machines for removing various adhesives and substrates from concrete.

WerkMaster Scarab Maintenance Checklist

ATTENTION: It is important that the WerkMaster Scarab go out to the end user with all included accessories. Ensure all moving parts in are in good working order.



DUST SKIRT

Ensure dust skirt is not chipped and in good working order. **A dust skirt that is broken may leak and release substrate material into the work area atmosphere.**

ULTRA-FLEX DRIVE™

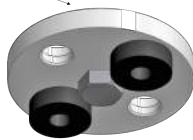

GROMMET

SURFACE PREPARATION

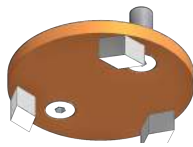

TOOLING
(full plate 16 grit
shark type)

ULTRA-FLEX DRIVE™

5 - ULTRA-FLEX DRIVE™ connected to machine output shaft. All ULTRA-FLEX DRIVE™ must include 2 grommets. Check for cracks and splits in grommets and replace prior to sending it out to rental.

SURFACE PREPARATION

For removing coating like Glue, Epoxy, Paint and Thinset use WerkMaster full 3 inch full plate 16 grit shark tooling.(rented)

GRINDING, REDUCE SCRATCHES

All other WerkMaster Tooling please refer to:
<http://www.werkmaster.com/machine-specific-tooling/>
To purchase from an authorized WerkMaster Dealer

TOOLING

Ensure all tooling has the same even wear and is of the same grit. **Unevenly worn tooling will result in poor performance on the substrate you are working on.** The tooling grit number is stamped on the front of tool.



Tooling Grit
Number

WARNING



SAFETY TOPICS:

Read the Operator's Manual or the Operation and Safety Guide and all of the safety precautions before attempting to operate WerkMaster machines. Failure to follow the safety precautions could result in severe personal injury or death. Please visit www.werkmaster.com

SAFETY CHECKLIST:

WARNING: ALWAYS turn the equipment off and unplug the power cord when changing discs/tooling, before servicing, and when not in use.



1. Before connecting the equipment to a power source make sure that is the correct voltage.
2. Ensure that all cords on the equipment are securely fastened and in good repair.
3. Ensure that all extension cords and power outlets are rated for the intended use, are in good repair, and are properly grounded (3 prong configuration).
4. Never operate the equipment under the influence of drugs or alcohol or when extremely fatigued.
5. If the equipment doesn't start or stops while running contact the rental dealer.
6. Follow all safety requirements pertaining to the polisher.



WARNING: Never turn the equipment on while it is tilted back. Any discs/tooling attached to the bottom could eject and become a lethal projectile.



Wear appropriate personal safety equipment such as hearing and eye protection and a dust mask or respirator.

Tool Application: The SCARAB™ attaches to a variable speed polisher to grind and/or polish a concrete surface. The SCARAB™ can be used for edging, getting to hard to reach areas, countertops, and stairs.

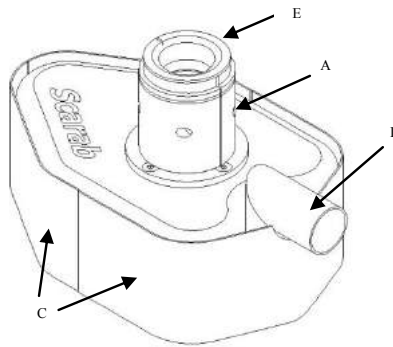

Fig.1

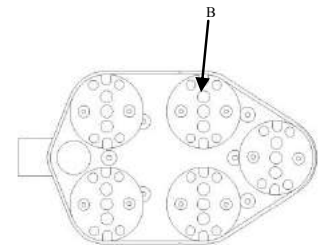

Fig.2

Tool Operation:







Step	Action
1	Ensure the polisher is turned off, unplugged and securely fastened to the SCARAB™. The 2 bolts (A) of the mounting coupler should be tight. The polisher should not be able to swivel. (Fig.1)
2	Tilt the equipment on its side (Fig.2). Choose the appropriate tooling holder attachment – 3" magnetic Plug 'N Go plate (B) for Metal bond tools or 3" Foam/Velcro Adapter plate for polishing resins. Insert the 2 shear pins into the rubber grommets. Then attach the corresponding tooling to the plate.
3	Lift the equipment back to the upright position. Loosen and lower the 3 sections of the dust skirt (C) so that they are just above the working surface. Connect the vacuum hose to the vacuum pipe (D). Turn speed on the polisher down to a low setting. Plug in the power cord.
4	With one hand grasp the handle bar on the polisher (not shown). To start the polisher, squeeze the activation trigger. Adjust the speed as required. To stop the equipment let go of the activation trigger.
5	When the equipment is in operation it should move smoothly and without chattering. If chattering or excessive vibration occurs stop the equipment, unplug the power cord, tilt it back and verify that all the tooling is seated properly
6	Move the equipment continuously in any direction using a circular motion. Be sure keep it moving at all times to prevent unwanted marks. View training video at www.werkmaster.com/scarab/ .
7	NOTE: There are 4 different mounting rings provided (E). They are designed to allow a Milwaukee, DeWalt, Flex, Metabo or Alpha variable speed grinder/polisher to be connected to the SCARAB™

WerkMaster Scarab Parts Re Order List

PARTS DESCRIPTION LIST FOR HOME DEPOT USE ONLY

Scarab Service Kit	008-0372-00	Includes 1 set of all Suggested On-Hand QTY items listed below	1
---------------------------	-------------	--	---

Ordering individual components of the Scarab Service Kit does not include shipping & handling. The costs are the responsibility of each THD Store.

IMAGE	PART #	DESCRIPTION	SUGGESTED ON-HAND QTY
	520-0034-00	Scarab Belt	2
	008-0407-00	3/8" Shear Pin & 6/32nd Screw Combo	10
	008-0207-00	3/8" Black Grommet Scarab/ Termite XT	20
	008-0208-00	1" Black Bumper Durom 70	20
	002-1375-00	3" - 16 Grit Medium Bond (Orange) Full Plate Tooling	5
	008-0233-00	Scarab Dust Skirt	2